

# Building Robots

----- FOR -----



Coaching Resources  
Ben Lipper

Build this robot – Chunking

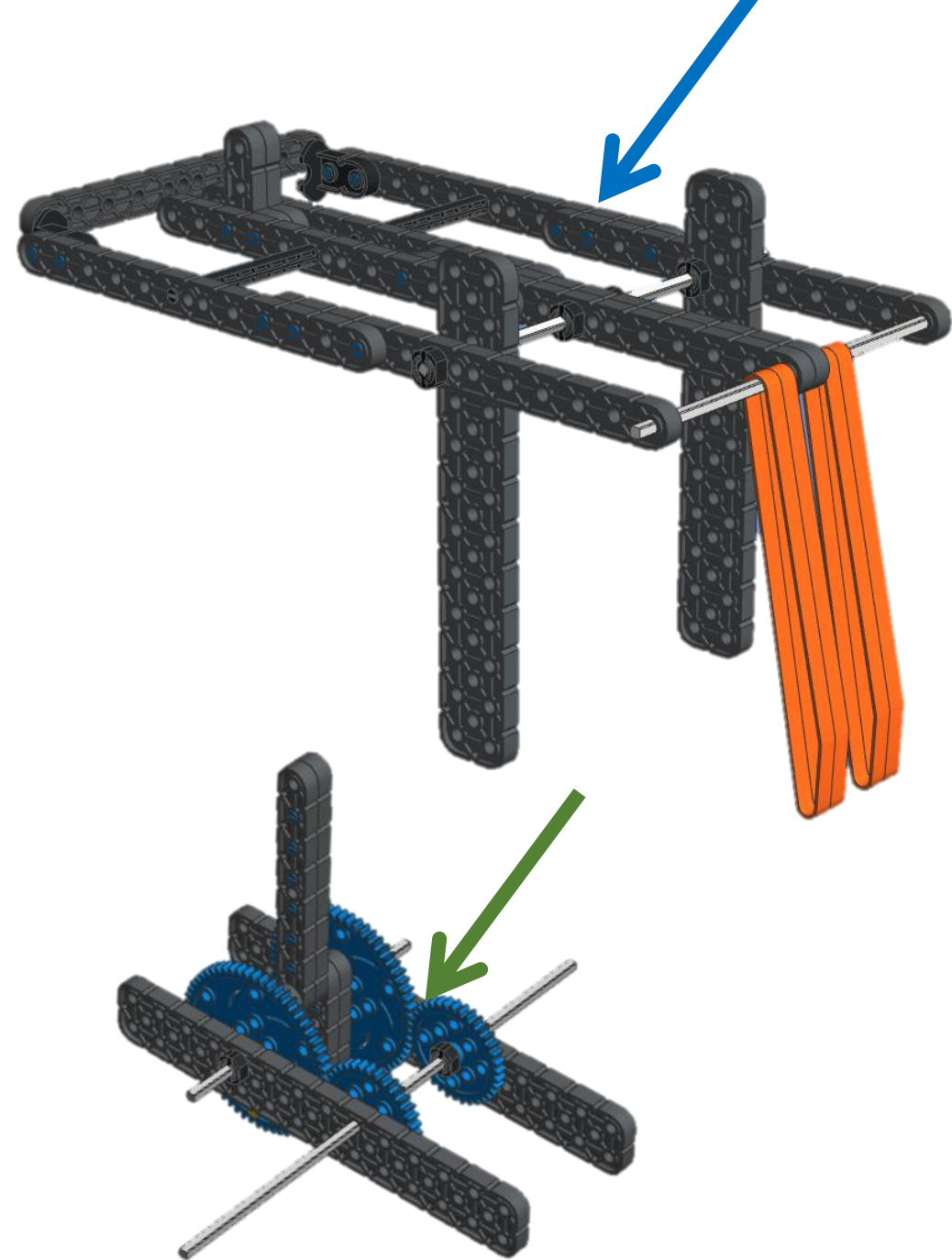
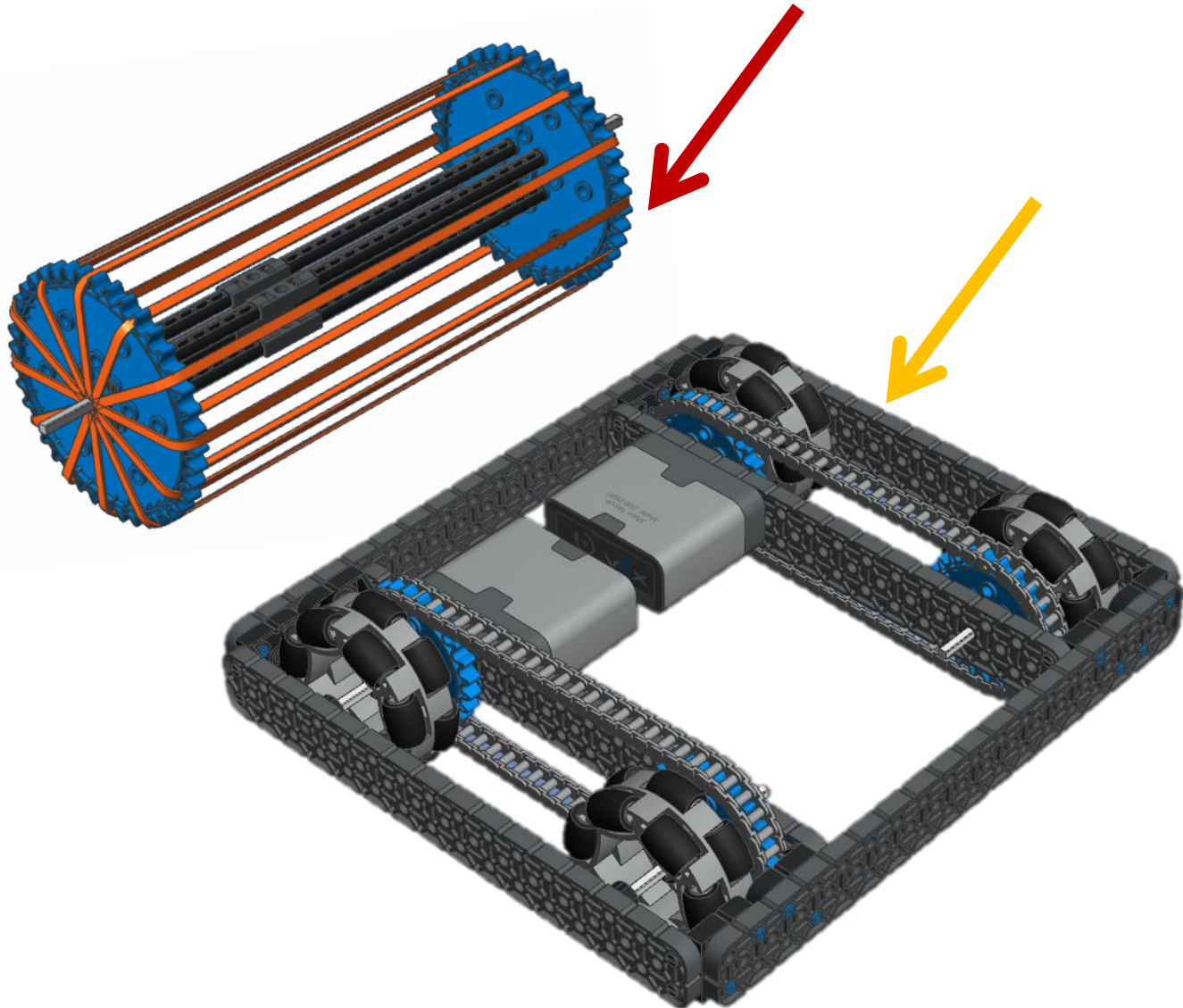

# Build this robot – Chunking

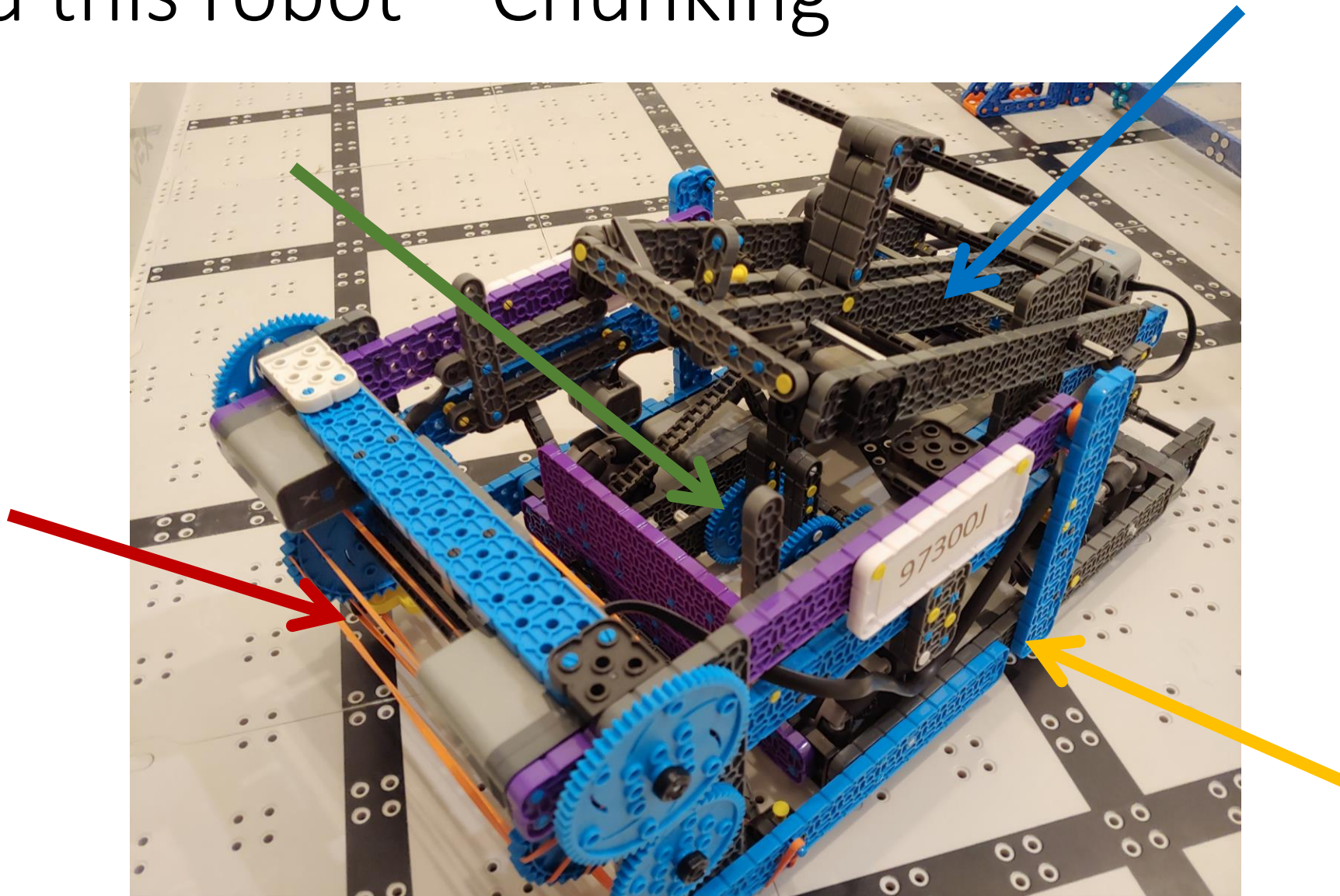

# Different robot models

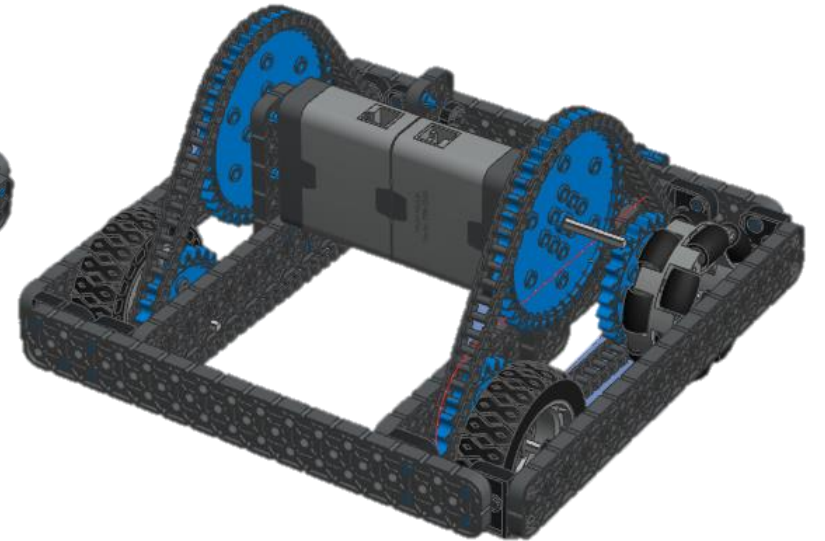
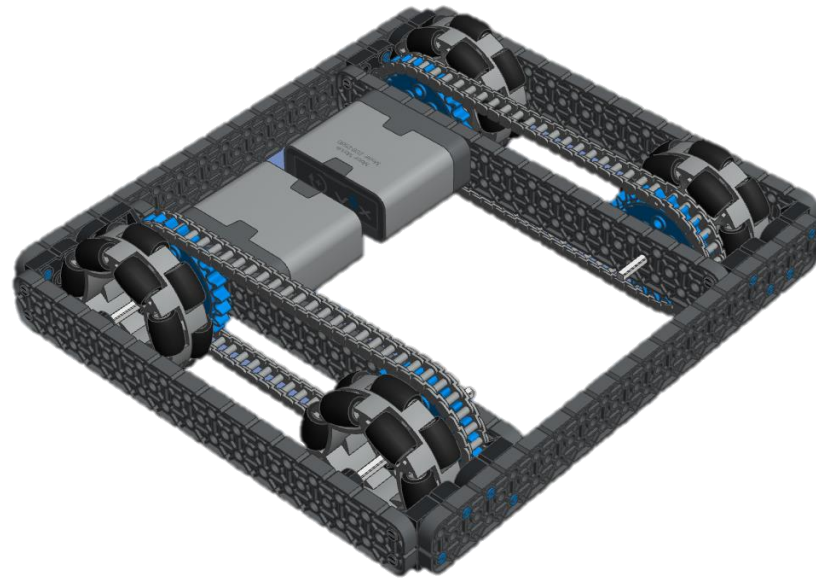
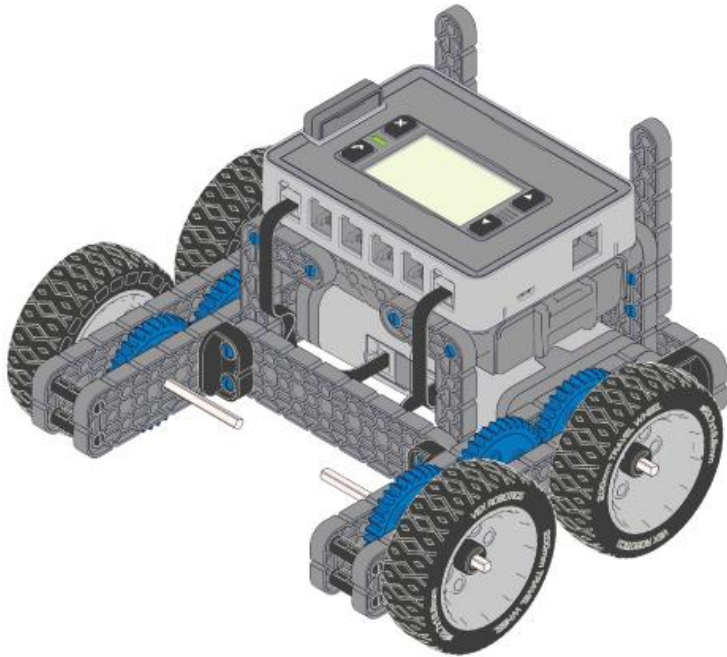

# Single-jointed arm - Geared

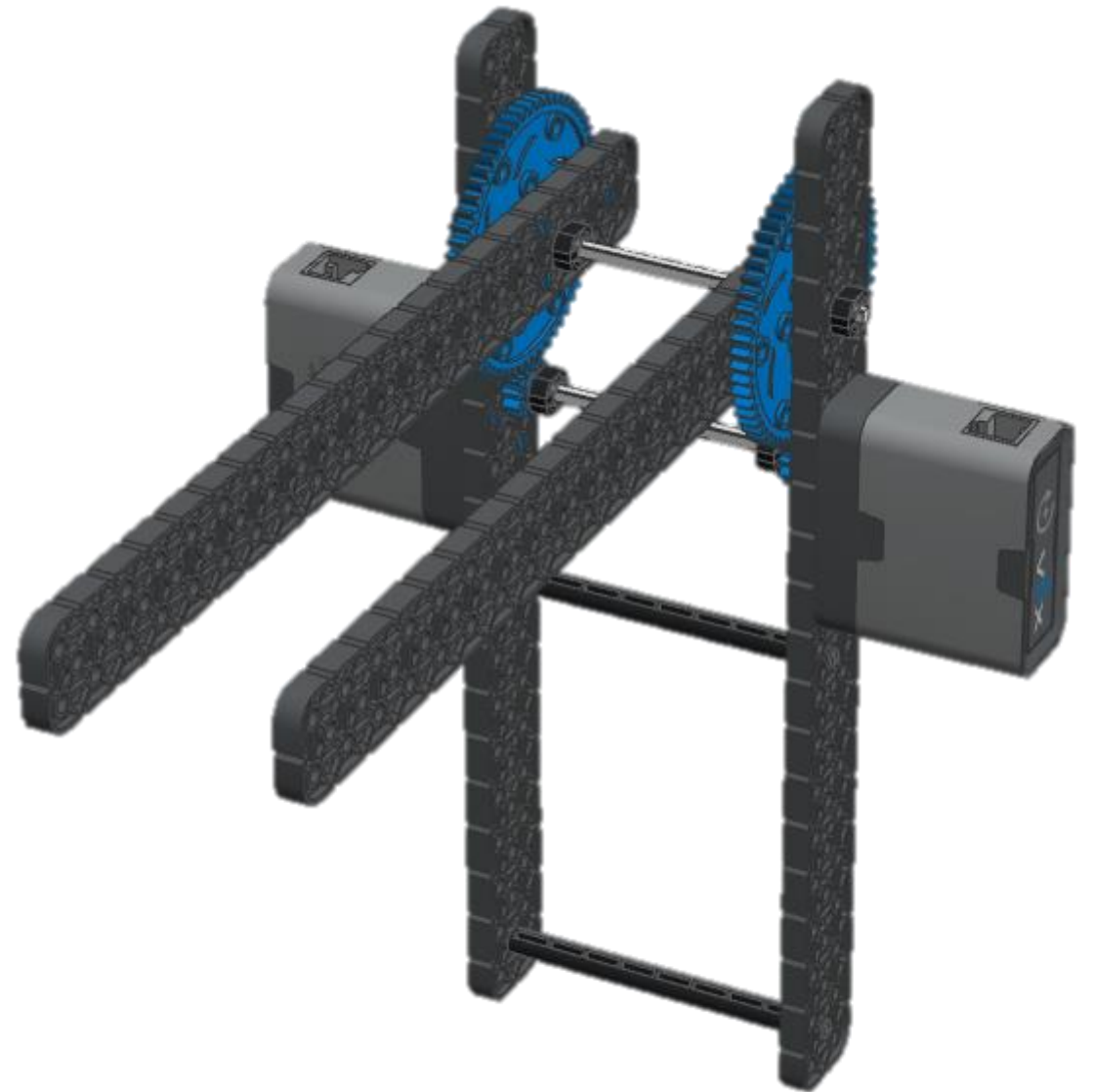

4-bar arm

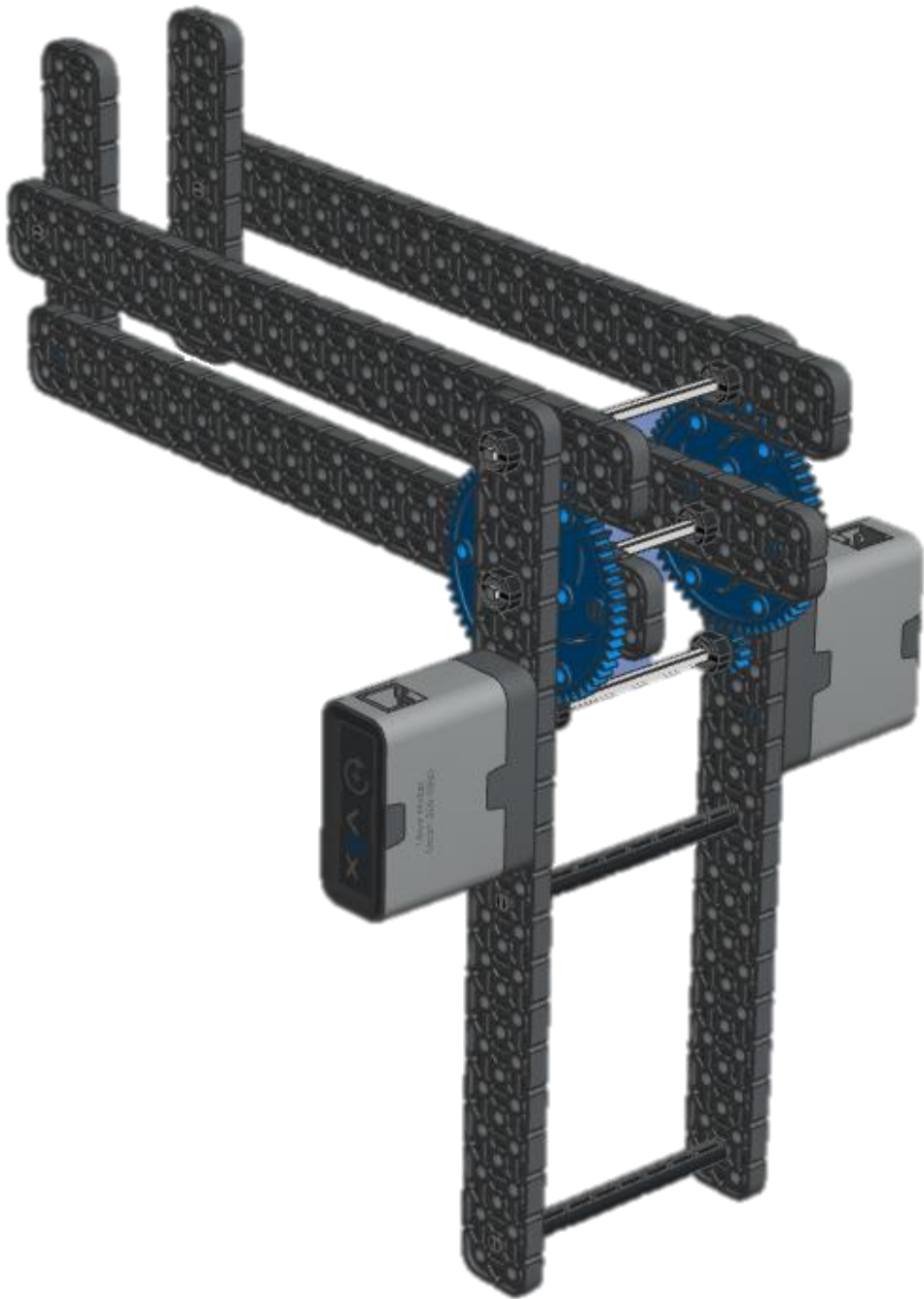



# Flywheels

Angular Kinetic Energy

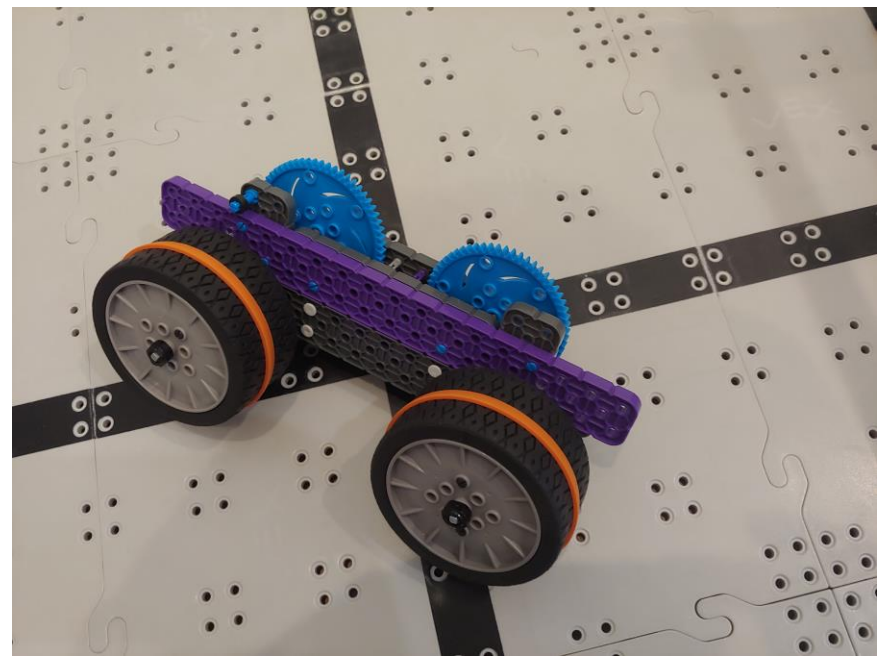
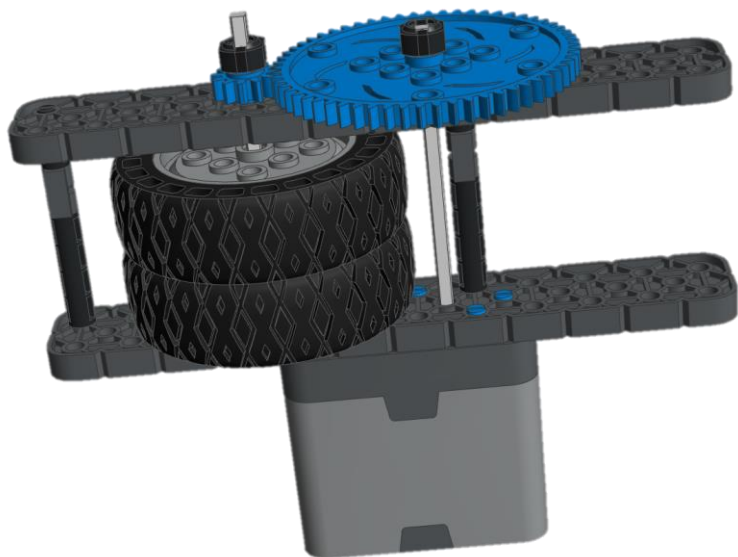

# Rubber-band arms

Catapults, Launchers, etc.

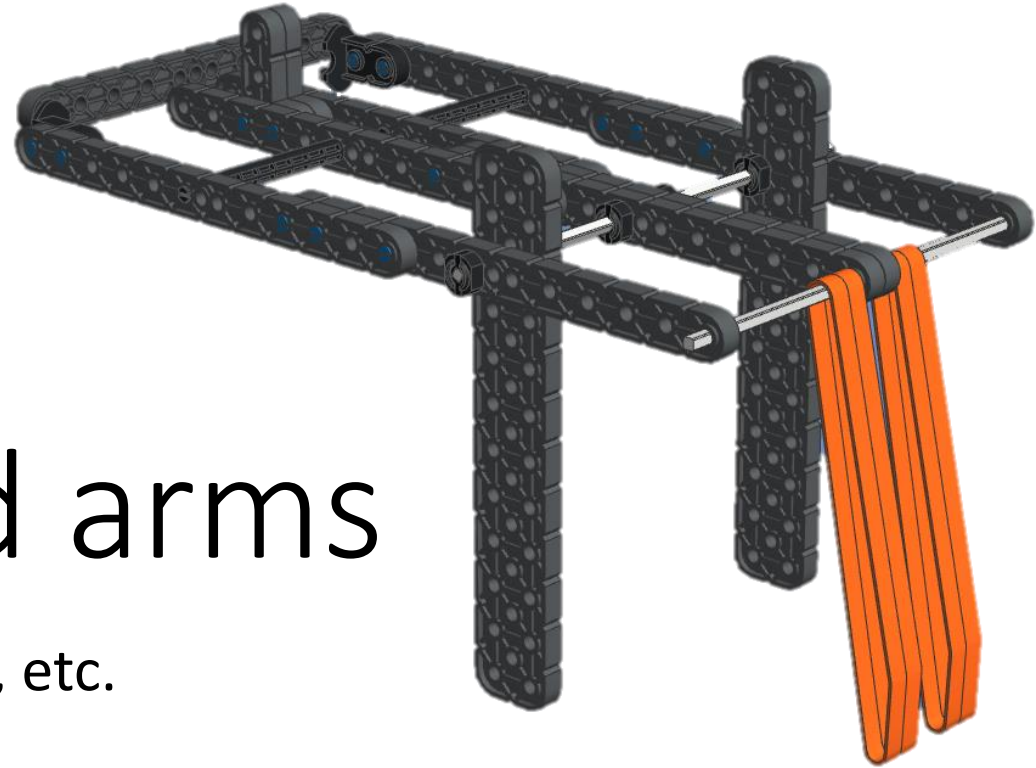



# Pull-back-and-release

- Simple star spinner
- Choo-Choo
- Slip-gear

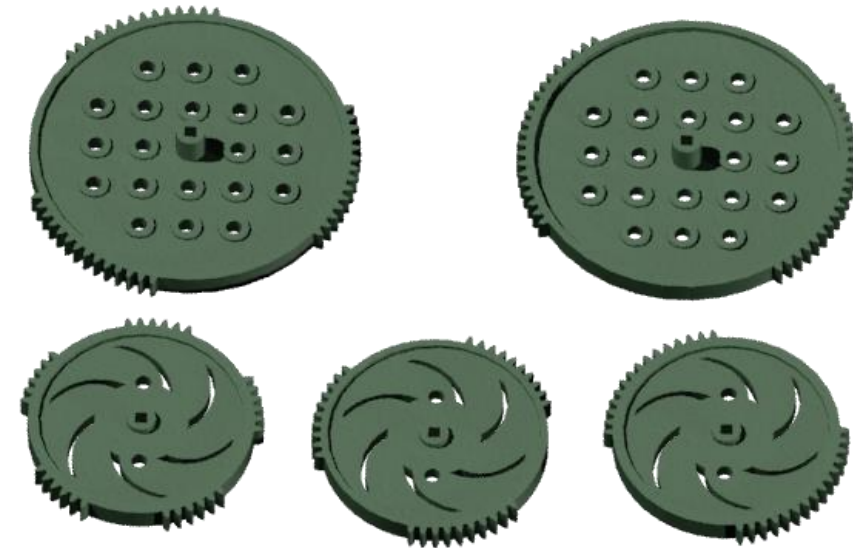
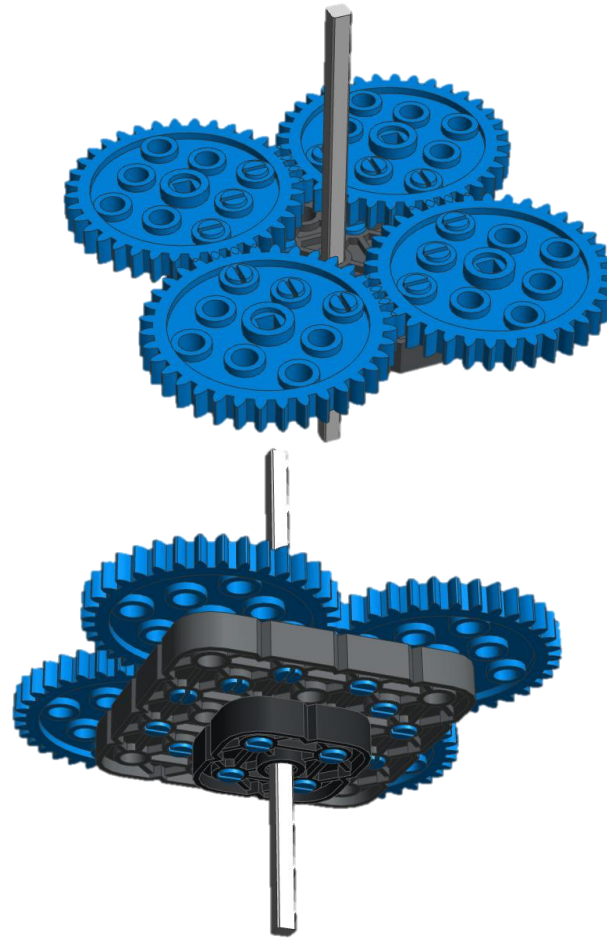
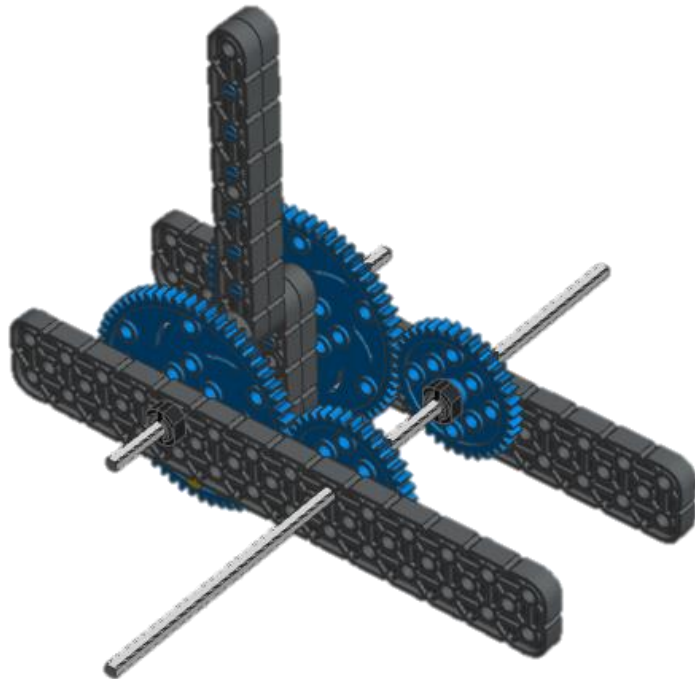
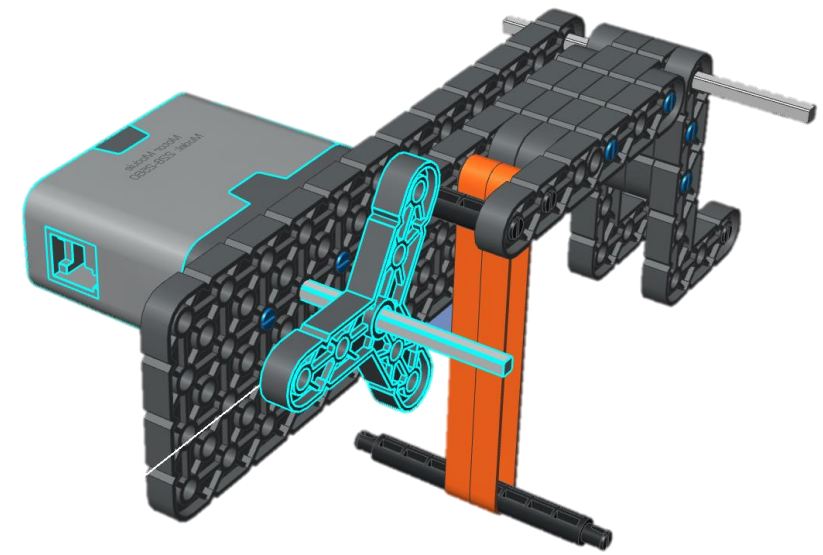

# Rolly-Grabbers

- Great for balls, small objects
- Not so great for large objects – use a claw

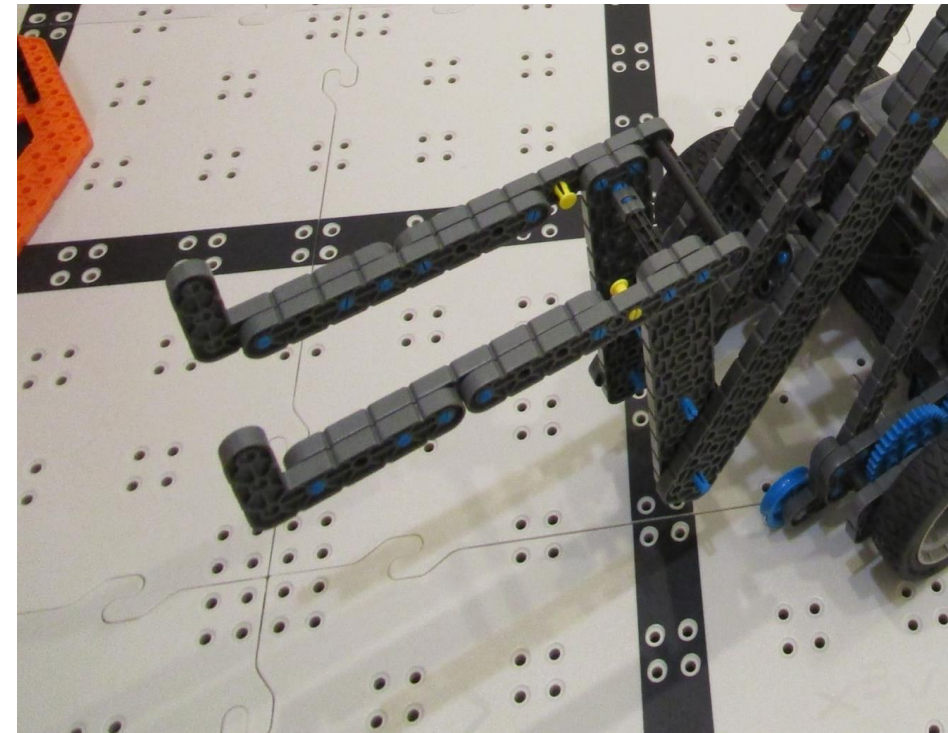
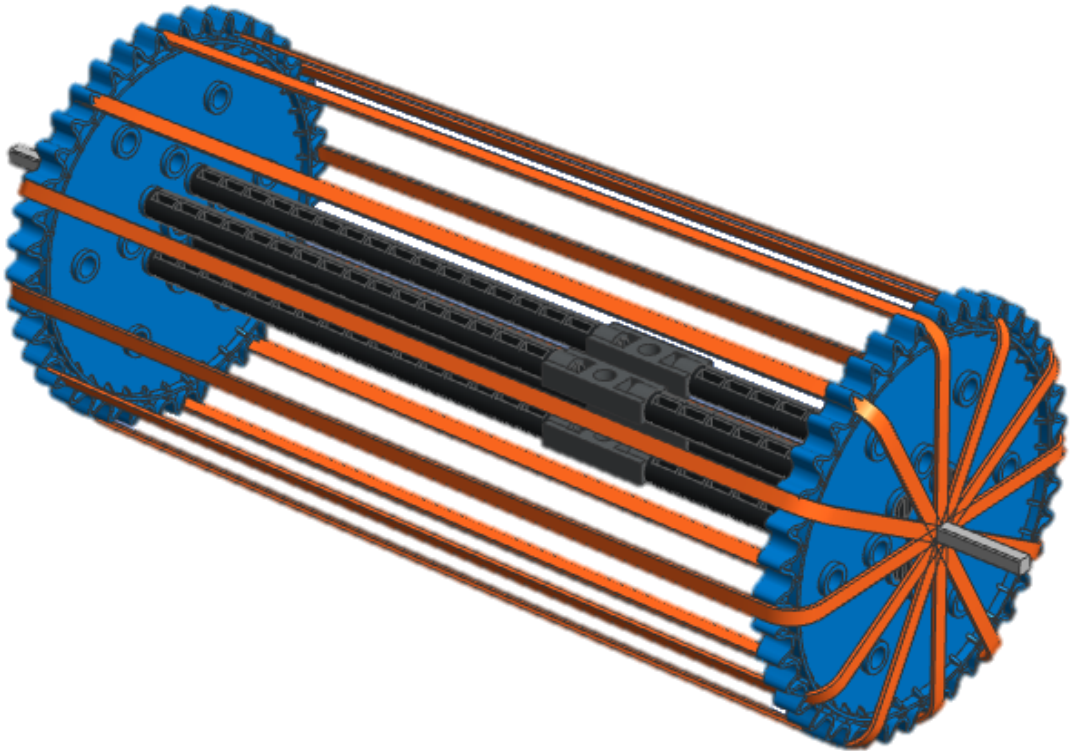

# Putting the subsystems together - Example

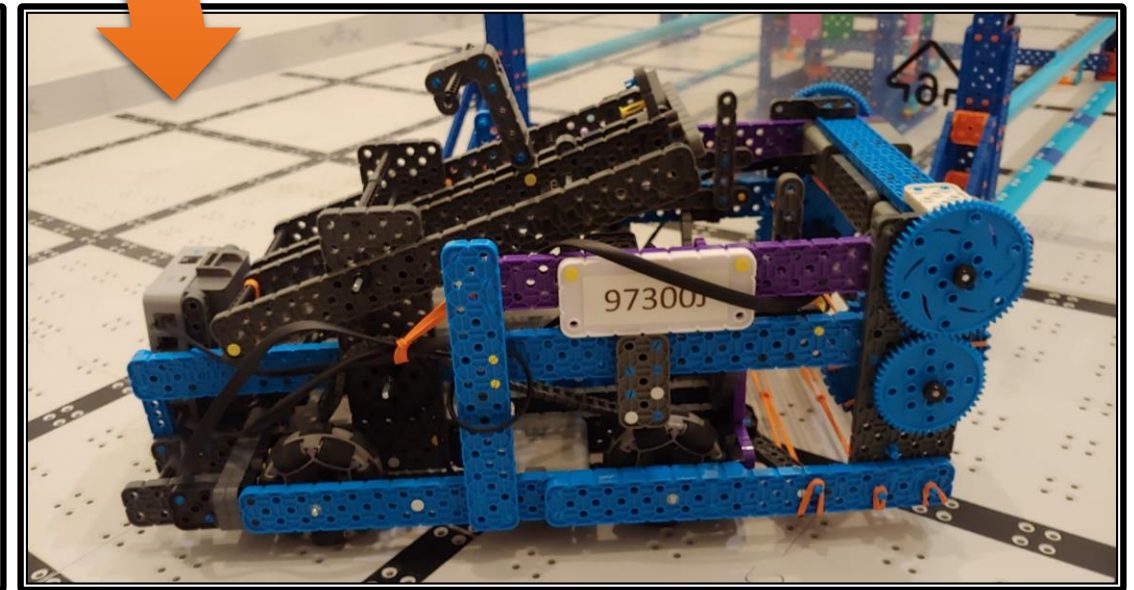
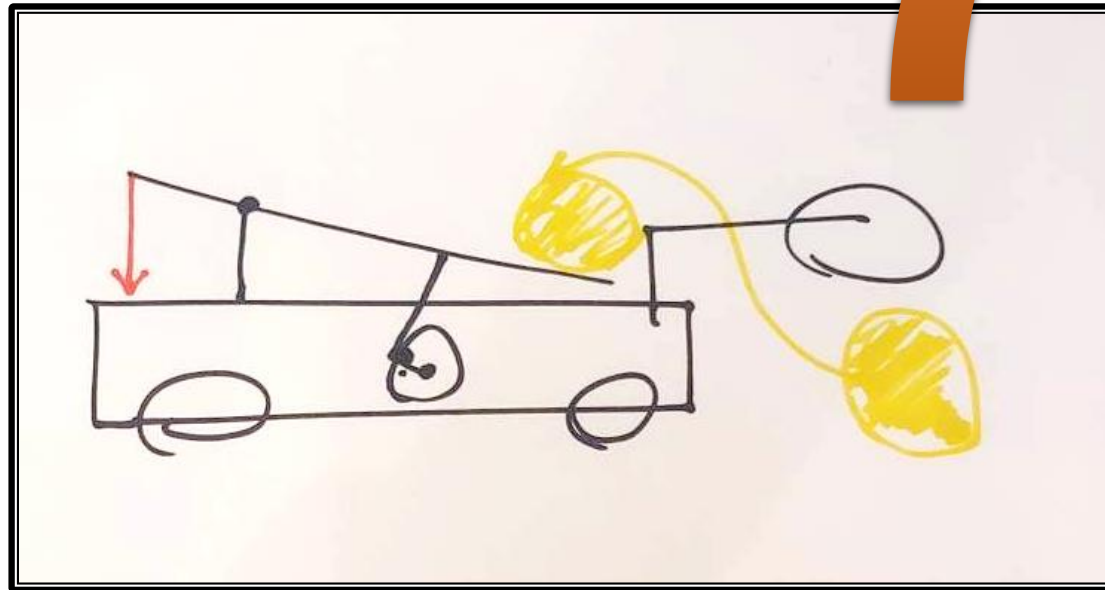

# Putting the subsystems together - Example

